

LCD Module Technical Specification

First Edition
Jun 13, 2006

Final Revision

Type No. **T-51570GD022J-MLW-AGN**

OPTREX CORPORATION

Approved : Minoru Akatsuka
QUALITY ASSURANCE DIVISION

Checked : Noboru Wada
ACI ENGINEERING DIVISION

Prepared : Takashi Yuchi
ACI ENGINEERING DIVISION

APPROVED

By

Signature :

Date :

Please return this specification within two month with your signature.
If not returned within two month ,specification will be considered
as having been accepted.

Table of Contents

- 1. General Specifications 3
- 2. Electrical Specifications 4
- 3. Optical Specifications 10
- 4. I/O Terminal 11
- 5. Test 13
- 6. Appearance Standards 14
- 7. Code System of Production Lot 18
- 8. Type Number 18
- 9. Applying Precautions 18
- 10. Precautions Relating Product Handling 19
- 11. Warranty 20

Revision History

Rev.	Date	Page	Comment

1.General Specifications

Operating Temp.	:	min. -20°C ~max. 70°C
Storage Temp.	:	min. -30°C ~max. 80°C
Resolution	:	176×3 [R.G.B] (W) × 220 (H) dots
Dot Pitch	:	0.06×3 [R.G.B] (W) × 0.198 (H) mm
Pixel Arrangement	:	RGB-stripe
Color Depth	:	260,000 colors
Active Viewing Area	:	34.848 (W) × 43.56 (H) mm
Outline Dimensions	:	40.8 (W) × 55.0 (H) × 3.6 (D) mm * Without FPC and Parts area
Weight	:	13.7g max.
LCD Type	:	Normally white-mode / Transflective
Viewing Angle	:	6:00
TFT Driver	:	Source Driver IS2100(ISRON) Gate Driver IS2200(ISRON)
Interface	:	18-bit RGB Interface 8-bit Serial Interface
Backlight	:	LED Backlight / White
Drawings	:	Dimensional Outline T-51570AG base
RoHS regulation	:	To our best knowledge, this product satisfies material requirement of RoHS regulation. Our company is doing the best efforts to obtain the equivalent certificate from our suppliers.

2. Electrical Specifications

2.1. Absolute Maximum Ratings

$V_{SS}=0V$

Parameter	Symbol	Conditions	Min.	Max.	Units
Supply Voltage	$V_{CC}-V_{SS}$	-	-0.3	5.0	V
Input Voltage	V_{IN}	-	-0.3	$V_{CC}+0.3$	V

2.2. DC Characteristics

$T_a=25^{\circ}C, V_{SS}=0V$

Parameter	Symbol	Conditions	Min.	Typ.	Max.	Units
Supply Voltage	$V_{CC}-V_{SS}$	-	2.7	2.8	2.9	V
High Level Input Voltage	V_{IH}	-	$0.8 \times V_{CC}$	-	V_{CC}	V
Low Level Input Voltage	V_{IL}	-	V_{SS}	-	$0.2 \times V_{CC}$	V
Supply Current	I_{CC}	Still Picture $V_{CC}-V_{SS}=2.8V$ without backlight Note	-	6.0	9.0	mA
		Stand-by mode $V_{CC}-V_{SS}=2.8V$ without backlight Note	-	38	57	μA

Note: The driving conditions are to be described.

2.3.AC Characteristics

2.3.1.RGB Interface

V_{CC}=2.7~2.9V

Parameter	Symbol	Min.	Max.	Units	
Dot Clock Cycle	t_{CLK}	500	-	ns	
Dot Clock High Pulse Width	t_{CLKH}	125	-	ns	
Dot Clock Low Pulse Width	t_{CLKL}	125	-	ns	
Data Setup Time	t_{DS}	60	-	ns	
Data Hold Time	t_{DH}	60	-	ns	
Hsync Pulse Width	t_{HSW}	1	-	Dotclk	
Hsync High Pulse Hold Time	t_{HH}	0	-	ns	
Horizontal Back Porch Time	t_{HBP}	1	-	Dotclk	
Horizontal Front Porch Time	t_{HFP}	1	-	Dotclk	
Hsync Cycle Time	t_{HS}	178	512	Dotclk	
Vsync Pulse Width	t_{VSW}	1	-	HS	
Vsync High Pulse Hold Time	t_{VH}	0	-	ns	
Vsync Cycle Time	R13:D0/NGO0=1	t_{VS}	225	-	HS
	R13:D0/NGO0=0		245	-	HS
Vertical Back Porch Time	t_{VBP}	1	-	HS	
Vertical Front Porch Time	t_{VFP}	1	-	HS	
Vsync Setup Time	t_{DL}	-	0	Dotclk	

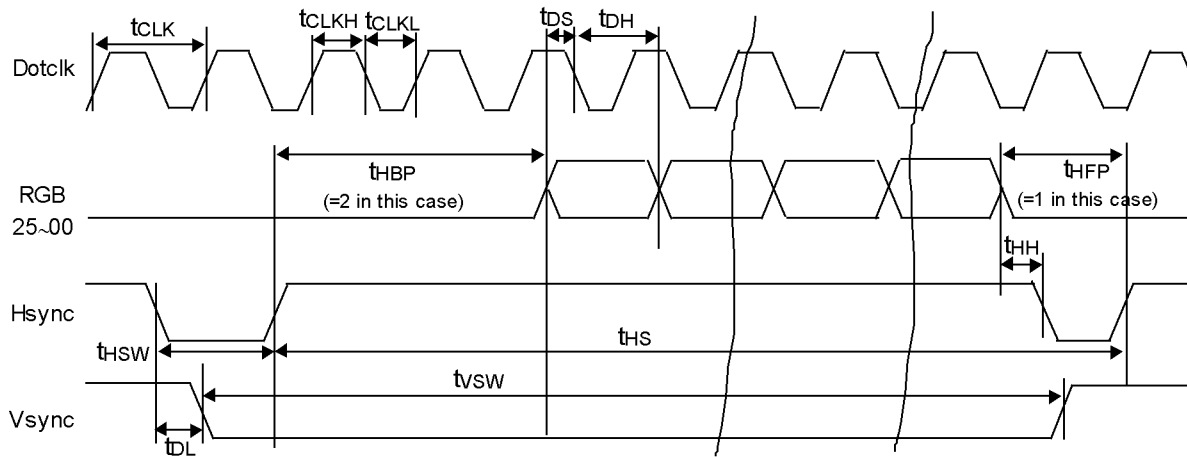

Horizontal Timing

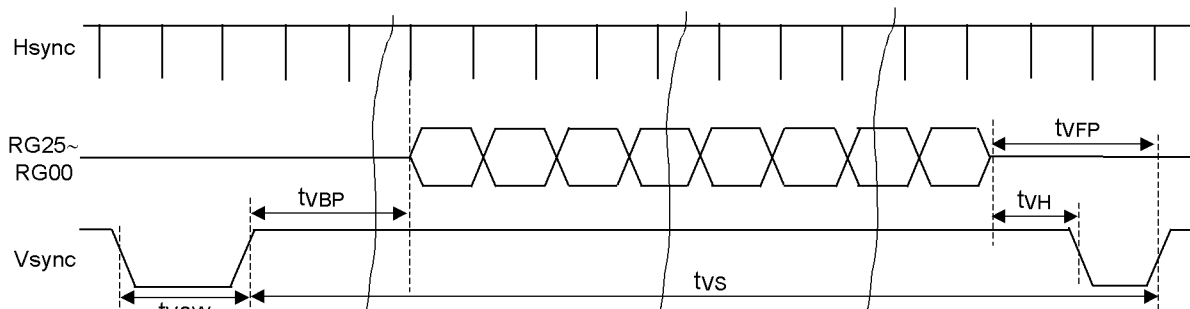

Vertical Timing

2.3.2. Serial Interface

V_{CC}=2.7~2.9V

Parameter	Symbol	Min.	Max.	Units
Serial Clock Cycle	t _{SCYC}	200	-	ns
SCL High Level Pulse Width	t _{SHW}	60	-	ns
SCL Low Level Pulse Width	t _{SLW}	85	-	ns
Address Hold Time	t _{SAH}	90	-	ns
Address Setup Time	t _{SAS}	90	-	ns
Data Setup Time	t _{SDS}	60	-	ns
Data Hold Time	t _{SDH}	60	-	ns
NCS~SCL Time	t _{CSS}	90	-	ns
	t _{CSH}	90	-	ns

t_r and t_f are regulated less than 15ns.

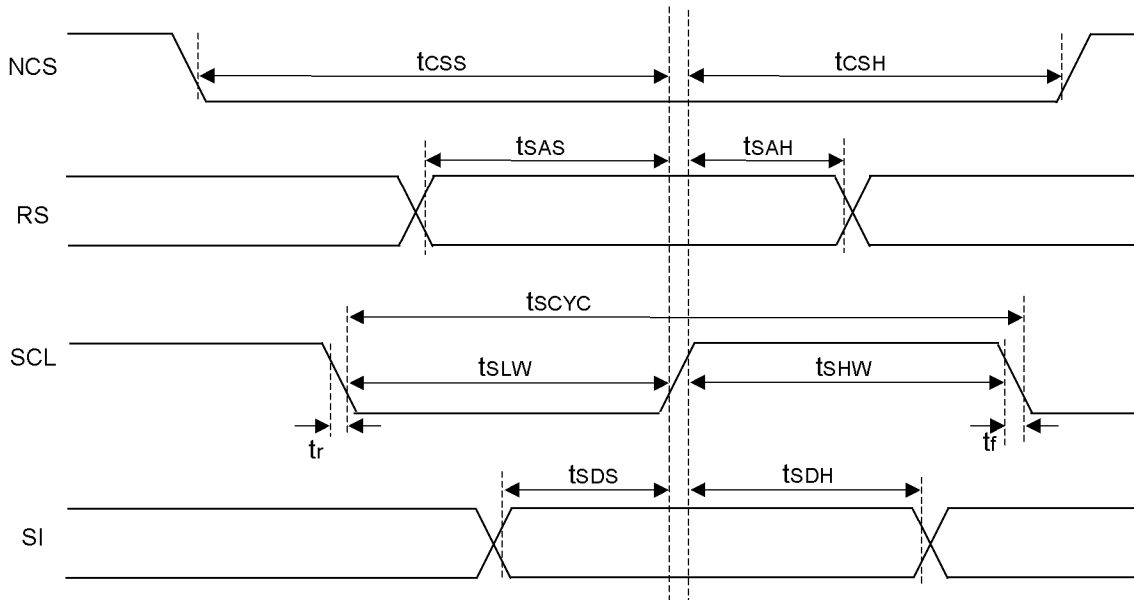

2.4. Display screen

Correspondence of graphic memory data and display screen

The software setting is to be determined.

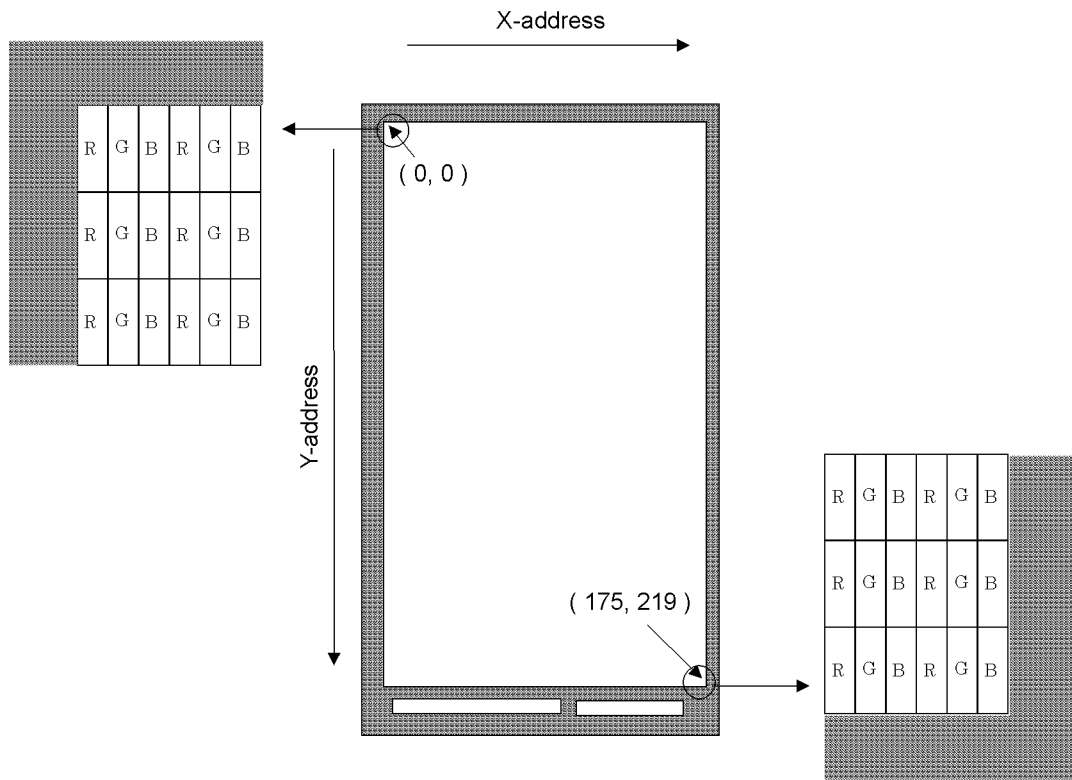

2.5. Lighting Specifications

2.5.1. Absolute Maximum Ratings (for one chip)

Ta=25°C

Parameter	Symbol	Conditions	Min.	Typ.	Max.	Units
Forward Current	I _F	-	-	-	30	mA
Reverse Voltage	V _R	-	-	-	5.0	V
LED Power Dissipation	P _D	-	-	-	120	mW

2.5.2. Operating Characteristics

Ta=25°C

Parameter	Symbol	Conditions	Min.	Typ.	Max.	Units
Forward Voltage	V _F	I _F =15mA	-	13.2	14.8	V
Luminance of Module Surface	L	I _F =15mA Note 1	50	70	-	cd/m ²
Uniformity Note 2	-	I _F =15mA	70	-	-	%

Note 1: The measurement method is to be determined.

Note 2: $\frac{\text{Luminance MIN}}{\text{Luminance MAX}} \times 100(\%)$

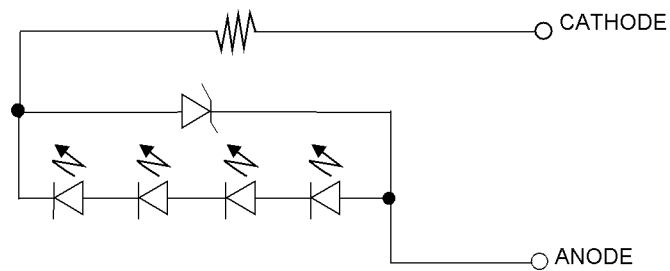

Measurement Points

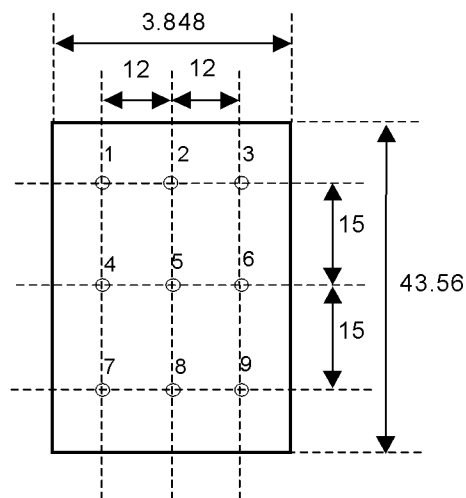

2.5.3. Color tone range (for LED chip only)

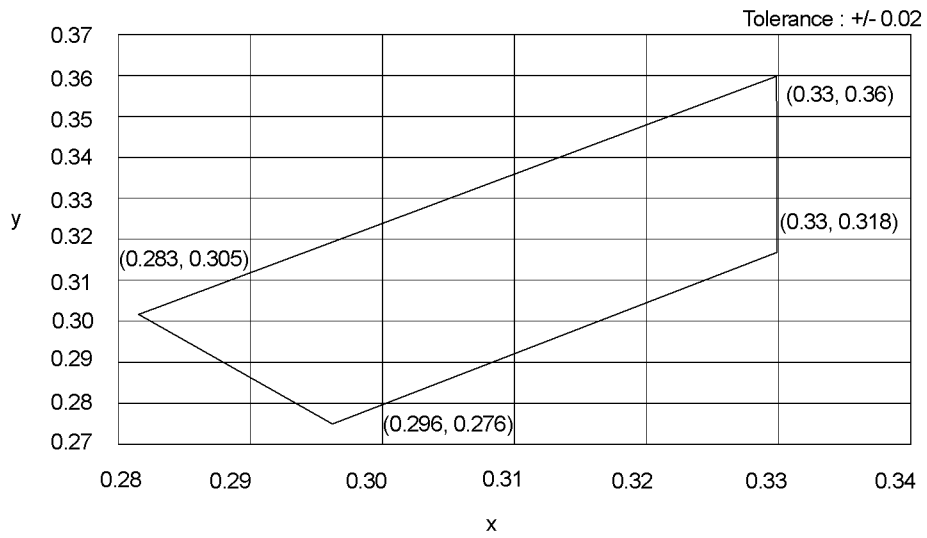

3. Optical Specifications

Item		Condition	Min	Typ	Max	Unit	Remarks
Brightness			80	120	-	cd/m ²	Note1
Reflectance			-	18	-	%	Note2
Viewing angle			6:00				
Contrast ratio	Transmission	25°C	70	100	-		
	Reflection	25°C	10	20	-		Note2
Response Time	Tr+Td	25°C	-	40	60	ms	
		-20°C	-	1100	1600	ms	
Color Area	Transmission		-	52	-		Note3
	Reflection		-	21	-		Note3
Color / transmission	White	x	-	0.301	-		
		y	-	0.342	-		
	Red	x	-	0.553	-		
		y	-	0.353	-		
	Green	x	-	0.321	-		
		y	-	0.505	-		
	Blue	x	-	0.144	-		
		y	-	0.173	-		
Color / reflection	White	x	0.278	0.323	0.368		Note2
		y	0.305	0.350	0.395		Note2
	Red	x	0.400	0.450	0.500		Note2
		y	0.298	0.343	0.388		Note2
	Green	x	0.260	0.305	0.350		Note2
		y	0.370	0.420	0.470		Note2
	Blue	x	0.117	0.162	0.207		Note2
		y	0.154	0.199	0.244		Note2

Note 1: 4 LEDs back light, 15mA/chip

Note 2: Ring light measurement

(15deg.incident light, detected at normal direction)

The reflectance of white calibration plate is 100%.

Note 3: The area of RGB triangle in (x, y) coordinates × 1000.

4.I/O Terminal

4.1.Pin Assignment

CN1

No.	Symbol	Function
1	Vss	Ground
2	Vcc	Power Supply
3	Vss	Ground
4	RGB25	RGB Data Bus
5	RGB24	RGB Data Bus
6	RGB23	RGB Data Bus
7	RGB22	RGB Data Bus
8	RGB21	RGB Data Bus
9	RGB20	RGB Data Bus
10	Vss	Ground
11	RGB15	RGB Data Bus
12	RGB14	RGB Data Bus
13	RGB13	RGB Data Bus
14	RGB12	RGB Data Bus
15	RGB11	RGB Data Bus
16	RGB10	RGB Data Bus
17	Vss	Ground
18	RGB05	RGB Data Bus
19	RGB04	RGB Data Bus
20	RGB03	RGB Data Bus
21	RGB02	RGB Data Bus
22	RGB01	RGB Data Bus
23	RGB00	RGB Data Bus
24	Vss	Ground
25	DOTCLK	Dot Clock for RGB Interface
26	HSYNk	RGB Interface Horizontal Synchronize Signal
27	VSYNk	RGB Interface Vertical Synchronize Signal
28	NBLCSI	Selection Pin for the Sub LCD Display
29	SO	Serial Data Output Pin
30	SCL	Serial Clock Input Pin
31	SI	Serial Data Input Pin
32	NRESET	Reset L : Reset H : Normal Operation
33	NCS	Chip Select L : Select H : Non Select
34	BLSDA	Serial Data Output for Sub LCD Display
35	BLSCL	Serial Clock Output for Sub LCD Display

36	NBLCSO	Chip Selection Output for Sub LCD Display
37	CSTB	Frame Synchronizing Signal (Same as Gframe)
38	RS	Data / Command Select Pin L : Command H : Display Data
39	LEDA	Backlight Power Supply (+) 15mA
40	LEDK	Backlight Power Supply (GND)

5. Test

No practical problems caused by any change on display and in operation under the following test condition.

Conditions: Unless otherwise specified, tests will be conducted under the following condition.

Temperature: $20\pm 5^{\circ}\text{C}$

Humidity : $65\pm 5\% \text{RH}$

Tests will be not conducted under operating state unless specified

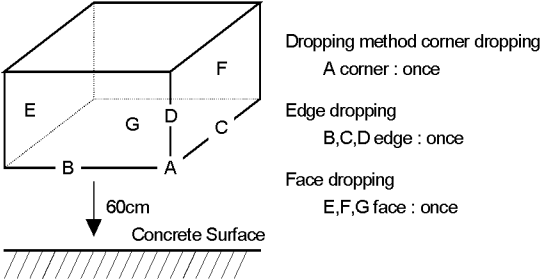
No.	Parameter	Conditions	Notes
1	High Temperature Operating	70°C , 240hrs (operation state)	1
2	Low Temperature Operating	-20°C , 240hrs (operation state)	2
3	High Temperature Storage	80°C , 240hrs	3
4	Low Temperature Storage	-30°C , 240hrs	2,3
5	Damp Proof Test	40°C , $90\% \text{RH}$, 240hrs	2,3
6	Heat Shock Test	-20°C to 70°C , 5cycles(both away) 1 hour duration at each temperature	2
7	Vibration Test	Total fixed amplitude : 1.5mm Vibration Frequency : 10~55Hz(60sec.sweep) Time duration : 15minutes for each x, y, z direction	3
8	Shock Test	To be measured after dropping from 60cm high to the concrete surface with shipping package. 	4

Note 1: It should be checked at the actual driving condition under the high temperature.

Note 2: No dew condensation is to be observed.

Note 3: The functional test shall be conducted after 4 hours storage at the room temperature and humidity after removed from the test chamber.

Note 4: Shock test will be conducted to the product itself without any actual set..

6.Appearance Standards

6.1.Inspection

The distance between the eyes and the sample shall be more than 30cm.
All directions for inspecting the sample should be within 45°against perpendicular line.

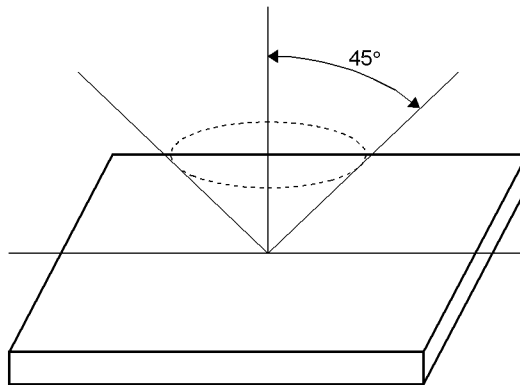

(a) Operating Inspection

The function and appearance shall be inspected in the condition of

- under 750 lx or over light ... Reflective Type.
- using over Backlight unit ... Transflective Type , Transmissive Type.

Condition of judgement

In case of no gradation display. It judges by applied On/Off voltage or optimal contrast.
In case of gradation display. It judges by contrast that the bad point is able to confirm best.

(b) Appearance Inspection

The appearance shall be inspected in the condition of

- under 500 lx or over light ... Reflective Type.
- using over Backlight unit ... Transflective Type , Transmissive Type.

(c) Inspection Environment

Inspection environment is carried out with 250 lx or less in principles.

6.2. Definition of applicable Zones

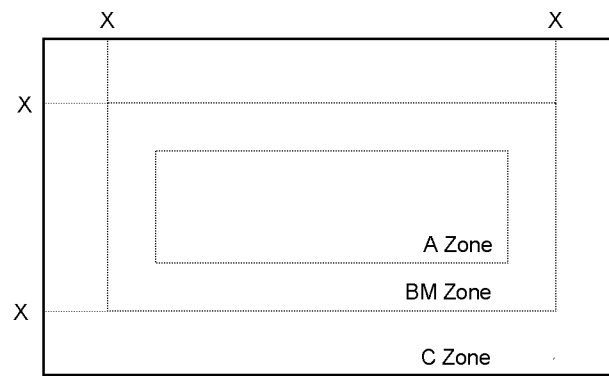

X : Maximum Seal Line

A Zone : Active display area

BM Zone : Out of active display area ~ Maximum seal line

C Zone : Rest parts

6.3.Standards

No.	Parameter	Criteria																																					
1	G Line	Nothing																																					
2	S Line	Nothing																																					
3	Leak	Nothing																																					
4	Bright and Dark dot	<table border="1"> <thead> <tr> <th>Zone</th> <th colspan="2">Acceptable Number</th> </tr> </thead> <tbody> <tr> <td rowspan="3">A</td> <td>Bright Dot</td> <td>2</td> </tr> <tr> <td>Adjacent Dot</td> <td>1</td> </tr> <tr> <td>Dark Dot</td> <td>3</td> </tr> <tr> <td>BM</td> <td>Bright Dot</td> <td>2</td> </tr> </tbody> </table> <p>* Adjacent Dot :Horizontal Continuous Bright dots *Vertical Continuous Bright dots are not allowed. *It is disregard when the bright dot area is smaller than 50% of the dot area. *It is disregard when invisible through 5% transmission ND filter.</p>	Zone	Acceptable Number		A	Bright Dot	2	Adjacent Dot	1	Dark Dot	3	BM	Bright Dot	2																								
Zone	Acceptable Number																																						
A	Bright Dot	2																																					
	Adjacent Dot	1																																					
	Dark Dot	3																																					
BM	Bright Dot	2																																					
5	Contrast Variation	Not to be conspicuous defects. Limit sample shall be determined by the arising demand.																																					
6	Black and White Spots, Foreign Material in Polarizer and LR/AR Coat Bright point	<p>(1) Round Shape</p> <table border="1"> <thead> <tr> <th rowspan="2">Dimension (mm) \ Zone</th> <th colspan="2">Acceptable Number</th> </tr> <tr> <th>A</th> <th>BM</th> </tr> </thead> <tbody> <tr> <td>$D \leq 0.10$</td> <td colspan="2">Disregard</td> </tr> <tr> <td>$0.10 < D \leq 0.15$</td> <td colspan="2">2</td> </tr> <tr> <td>$0.15 < D \leq 0.20$</td> <td colspan="2">1</td> </tr> <tr> <td>$0.20 < D$</td> <td colspan="2">0</td> </tr> </tbody> </table> <p>$D = (Long + Short) / 2$</p> <p>(2) Line Shape</p> <table border="1"> <thead> <tr> <th rowspan="2">X(mm) \ Y(mm) \ Zone</th> <th colspan="2">Acceptable Number</th> </tr> <tr> <th>A</th> <th>BM</th> </tr> </thead> <tbody> <tr> <td>- \ $W \leq 0.01$</td> <td colspan="2">Disregard</td> </tr> <tr> <td>$L \leq 2.0$ \ $W \leq 0.02$</td> <td colspan="2">2</td> </tr> <tr> <td>$L \leq 1.0$ \ $W \leq 0.03$</td> <td colspan="2">1</td> </tr> <tr> <td>$L > 2.0$ \ -</td> <td colspan="2">0</td> </tr> <tr> <td>- \ $W > 0.03$</td> <td colspan="2">0</td> </tr> </tbody> </table> <p>X : Length Y : Width Limit sample shall be determined by the arising demand.</p>	Dimension (mm) \ Zone	Acceptable Number		A	BM	$D \leq 0.10$	Disregard		$0.10 < D \leq 0.15$	2		$0.15 < D \leq 0.20$	1		$0.20 < D$	0		X(mm) \ Y(mm) \ Zone	Acceptable Number		A	BM	- \ $W \leq 0.01$	Disregard		$L \leq 2.0$ \ $W \leq 0.02$	2		$L \leq 1.0$ \ $W \leq 0.03$	1		$L > 2.0$ \ -	0		- \ $W > 0.03$	0	
Dimension (mm) \ Zone	Acceptable Number																																						
	A	BM																																					
$D \leq 0.10$	Disregard																																						
$0.10 < D \leq 0.15$	2																																						
$0.15 < D \leq 0.20$	1																																						
$0.20 < D$	0																																						
X(mm) \ Y(mm) \ Zone	Acceptable Number																																						
	A	BM																																					
- \ $W \leq 0.01$	Disregard																																						
$L \leq 2.0$ \ $W \leq 0.02$	2																																						
$L \leq 1.0$ \ $W \leq 0.03$	1																																						
$L > 2.0$ \ -	0																																						
- \ $W > 0.03$	0																																						

No.	Parameter	Criteria																	
7	Color Variation	Not to be conspicuous defects. Limit sample shall be determined by the arising demand. However, about the Color patches shall be two pieces or less which are same level as the limit sample.																	
8	Air Bubbles (between glass and polarizer)	<table border="1"> <thead> <tr> <th rowspan="2">Zone Dimension (mm)</th> <th colspan="2">Acceptable Number</th> </tr> <tr> <th>A</th> <th>BM</th> </tr> </thead> <tbody> <tr> <td>$D \leq 0.10$</td> <td colspan="2">Disregard</td> </tr> <tr> <td>$0.10 < D \leq 0.15$</td> <td colspan="2">1</td> </tr> <tr> <td>$0.15 < D \leq 0.20$</td> <td colspan="2">1</td> </tr> <tr> <td>$< D \leq 0.20$</td> <td colspan="2">0</td> </tr> </tbody> </table> <p>The polarizer edge has not floated. Limit sample shall be determined by the arising demand.</p>	Zone Dimension (mm)	Acceptable Number		A	BM	$D \leq 0.10$	Disregard		$0.10 < D \leq 0.15$	1		$0.15 < D \leq 0.20$	1		$< D \leq 0.20$	0	
Zone Dimension (mm)	Acceptable Number																		
	A	BM																	
$D \leq 0.10$	Disregard																		
$0.10 < D \leq 0.15$	1																		
$0.15 < D \leq 0.20$	1																		
$< D \leq 0.20$	0																		
9	Polarizer Scratches, Stroke marks	Not to be conspicuous defects. Limit sample shall be determined by the arising demand.																	
10	Polarizer Dirts	If the stains are removed easily from LCDP surface, the module is not defective.																	

7.Code System of Production Lot

The production lot of module is specified as follows.

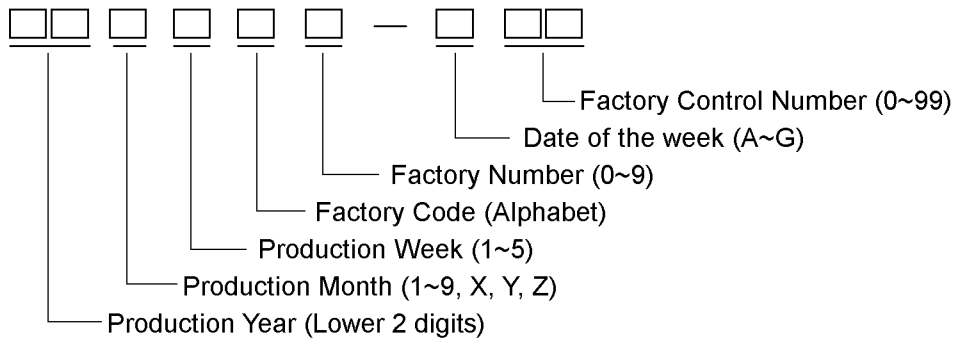

8.Type Number

The type number of module is specified as follows.

51570AG

9.Precautions under operation

When questions arise concerning this specifications or new problems not specified in this specifications arise, problems related to the specification is to be discussed for solution.

10.Precautions Relating Product Handling

The Following precautions will guide you in handling our product correctly.

- 1) Liquid crystal display devices
 1. The liquid crystal display device panel used in the liquid crystal display module is made of plate glass. Avoid any strong mechanical shock. Should the glass break handle it with care.
 2. The polarizer adhering to the surface of the LCD is made of a soft material. Guard against scratching it.
- 2) Care of the liquid crystal display module against static electricity discharge.
 1. When working with the module, be sure to ground your body and any electrical equipment you may be using. We strongly recommend the use of anti static mats (made of rubber), to protect work tables against the hazards of electrical shock.
 2. Avoid the use of work clothing made of synthetic fibers. We recommend cotton clothing or other conductivity-treated fibers.
 3. Slowly and carefully remove the protective film from the LCD module, since this operation can generate static electricity.
- 3) When the LCD module alone must be stored for long periods of time:
 1. Protect the modules from high temperature and humidity.
 2. Keep the modules out of direct sunlight or direct exposure to ultraviolet rays.
 3. Protect the modules from excessive external forces.
- 4) Use the module with a power supply that is equipped with an overcurrent protector circuit, since the module is not provided with this protective feature.
- 5) Do not ingest the LCD fluid itself should it leak out of a damaged LCD module. Should hands or clothing come in contact with LCD fluid, wash immediately with soap.
- 6) Conductivity is not guaranteed for models that use metal holders where solder connections between the metal holder and the PCB are not used. Please contact us to discuss appropriate ways to assure conductivity.
- 7) For models which use CFL:
 1. High voltage of 1000V or greater is applied to the CFL cable connector area. Care should be taken not to touch connection areas to avoid burns.
 2. Protect CFL cables from rubbing against the unit and thus causing the wire jacket to become worn.
 3. The use of CFLs for extended periods of time at low temperatures will significantly shorten their service life.
- 8) For models which use touch panels:
 1. Do not stack up modules since they can be damaged by components on neighboring modules.
 2. Do not place heavy objects on top of the product. This could cause glass breakage.
- 9) For models which use COG, TAB, or COF:
 1. The mechanical strength of the product is low since the IC chip faces out unprotected from the rear. Be sure to protect the rear of the IC chip from external forces.
 2. Given the fact that the rear of the IC chip is left exposed, in order to protect the unit from electrical damage, avoid installation configurations in which the rear of the IC chip runs the risk of making any electrical contact.

- 10) Models which use flexible cable, heat seal, or TAB:
 1. In order to maintain reliability, do not touch or hold by the connector area.
 2. Avoid any bending, pulling, or other excessive force, which can result in broken connections.

- 11) In case of buffer material such as cushion / gasket is assembled into LCD module, it may have an adverse effect on connecting parts (LCD panel-TCP / HEAT SEAL / FPC / etc., PCB-TCP / HEAT SEAL / FPC etc., TCP-HEAT SEAL, TCP-FPC, HEAT SEAL-FPC, etc.,) depending on its materials.
Please check and evaluate these materials carefully before use.

- 12) In case of acrylic plate is attached to front side of LCD panel, cloudiness (very small cracks) can occur on acrylic plate, being influenced by some components generated from polarizer film..
Please check and evaluate those acrylic materials carefully before use.

11. Warranty

This product has been manufactured to your company's specifications as a part for use in your company's general electronic products. It is guaranteed to perform according to delivery specifications. For any other use apart from general electronic equipment, we cannot take responsibility if the product is used in medical devices, nuclear power control equipment, aerospace equipment, fire and security systems, or any other applications in which there is a direct risk to human life and where extremely high levels of reliability are required. If the product is to be used in any of the above applications, we will need to enter into a separate product liability agreement.

1. We cannot accept responsibility for any defect, which may arise from additional manufacturing of the product (including disassembly and reassembly), after product delivery.
2. We cannot accept responsibility for any defect, which may arise after the application of strong external force to the product.
3. We cannot accept responsibility for any defect, which may arise due to the application of static electricity after the product has passed your company's acceptance inspection procedures.
4. When the product is in CFL models, CFL service life and brightness will vary According to the performance of the inverter used, leaks, etc. We cannot accept responsibility for product performance, reliability, or defect, which may arise.
5. We cannot accept responsibility for intellectual property of a third party, which may arise through the application of our product to your assembly with exception to those issues relating directly to the structure or method of manufacturing of our product.
6. Optrex will not be held responsible for any quality guarantee issue for defect products judged as Optrex-origin longer than 2 (two) years from Optrex production or 1(one) year from Optrex, Optrex America, Optrex Europe delivery which ever comes later.